



THIS MANUAL IS AVAILABLE FOR FREE  
COMPLIMENTS OF

**BUYMEBUYME.COM**

**TO ORDER THIS PRODUCT, PLEASE CALL TOLL-FREE  
1-877-992-8963 OR VISIT [WWW.BUYMEBUYME.COM](http://WWW.BUYMEBUYME.COM)**



USER'S MANUAL  
Part 2

## Two-Line Speakerphone 952

---

*Fold open this manual for information about this telephone's installation and operation. Please also read **Part 1 — Important Product Information.***



For Customer Service Or Product  
Information, Visit Our Website At  
[www.telephones.att.com](http://www.telephones.att.com)

AT&T and the globe symbol are registered trademarks of AT&T Corp. licensed to Advanced American Telephones.

© 2001 Advanced American Telephones. All rights reserved.  
Printed in China. Issue 1AT&T 7/01

# INSTALLATION

## Before You Install

**NOTE:** To use this product as a two-line phone, you must have a two-line modular jack or two separate one-line modular jacks. To use both lines of a two-line telephone, your local telephone company must provide two telephone numbers.

## Batteries

Before using the telephone, you should install four AA batteries (not included). If you are connecting only Line 1 or only Line 2, use two batteries, as indicated on the bottom of the phone. If you are connecting both lines, use four batteries.

You can use the phone without batteries to dial and receive calls using the handset, but it requires batteries to power the Line Status lights, the headset, and the Auto Redial feature.

- 1 Turn the telephone upside down (Figure 1).
- 2 Remove the base by pressing the tabs located on the top of the base.
- 3 Press down on the tab located between the arrows on battery cover (Figure 2). Remove the battery cover and insert new AA batteries, not included (Figure 3).
- 4 Replace the battery cover.



**CAUTION:** Always unplug the line cord before installing new AA batteries.

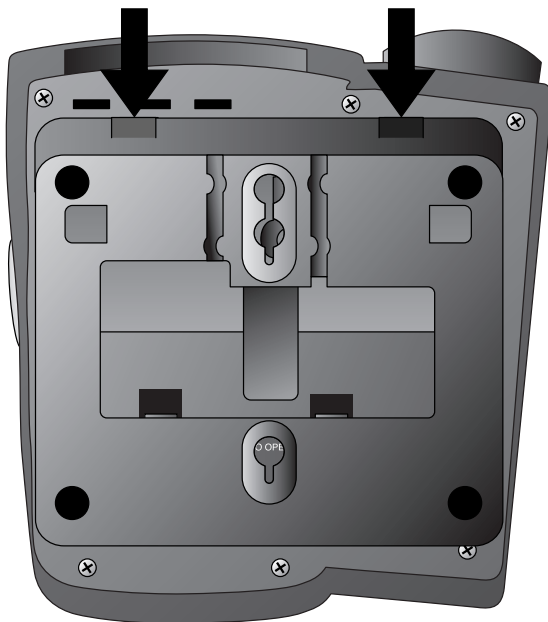

Figure 1

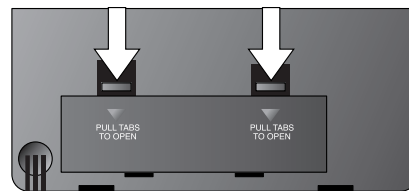

Figure 2

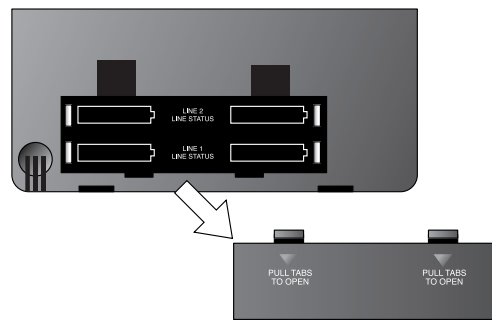

Figure 3

# INSTALLATION

## Table/Desk

### 1 Connect line cord(s) to telephone.

- If you have a two-line jack, use only the line cord with the clear modular plugs on each end. Plug one end into the jack labeled **L1** OR **L1/L2** on the back of the telephone.
- If you have two separate jacks, use both line cords. Insert one end of the cord with the blue plugs into the jack labeled **L1** OR **L1/L2** on the back of the telephone. Insert one end of the cord with the clear plugs into the jack labeled **L2** on the back of the telephone.

### 2 Attach the base.

Turn the base so that the larger end of the base is toward the top of the telephone. Attach the base by inserting the tabs into the slots. Push down on the large end of the base to lock it into place.

### 3 Connect the line cord(s) to your modular jack(s).

- **If you have a two-line jack**, plug the free end of the line cord into a modular telephone jack. Make sure the cord snaps firmly into place.

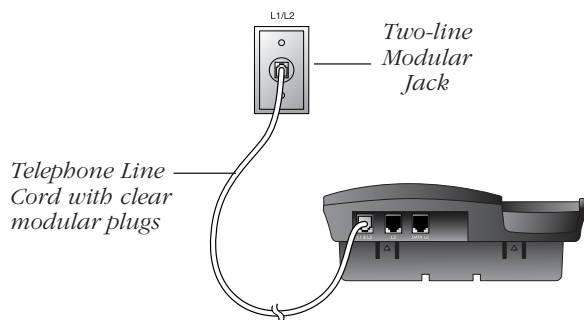

- **If you have two separate jacks**, plug the free end of the cord with the blue plugs into the modular jack for Line 1. Plug the free end of the cord with the clear plugs into the modular telephone jack for Line 2. Make sure the cords snap firmly into place.

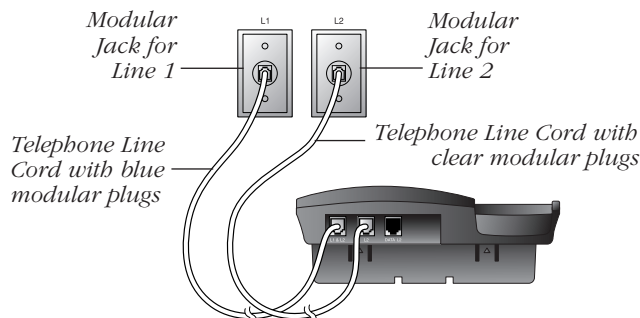

### 4 Connect handset to telephone.

### 5 Set Dial Mode.

This product comes set for touch tone dialing. Make sure you choose the correct dialing method (TONE or PULSE); dial pulse dialing will not work if you have touch tone service.

To set for dial pulse (rotary) service, lift handset and press **LINE 1** or **LINE 2**, then press **PROG**, **#**, **#**, **#**, **3**. To change back to touch tone service, press **PROG**, **#**, **#**, **#**, **8**.

To switch from pulse to tone dialing during a phone call, see "Temporary Tone" under TELEPHONE OPERATION.

### 6 Check for dial tone.

Press **LINE 1**, lift the handset, press **SPEAKER** or press **HEADSET**, and listen for a dial tone. Then press **LINE 2**. If you cannot hear a dial tone, turn to IN CASE OF DIFFICULTY.

### 7 Confirm Lines 1 and 2.

To determine which line is which, press **LINE 1** and call one of your telephone numbers. If you hear a busy signal, Line 1 is the number you called. If Line 2 rings, it is the number you called.

## Data Port

If you want to connect another device (such as a modem or fax machine) to the wall jack, you can use the jack on the phone labeled **DATA L2**. The data port uses Line 2; a call picked up on Line 2 at another extension may interrupt a fax, modem, or message transmission.

## Headset Jack

You can use this telephone hands-free when you install any AT&T 2.5 mm headset, purchased separately.

Plug the headset into the jack. Do not force the connection, but make sure the plug fits securely.

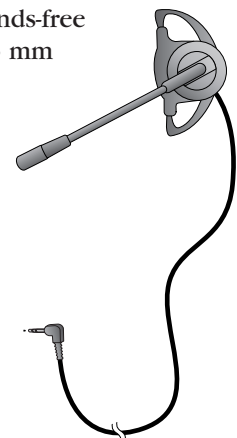

# INSTALLATION

## Wall

### 1 Connect bundled line cord(s) to the telephone.

Leave the telephone line cord(s) bundled.

- **If you have a two-line wall jack**, use only the line cord with the clear modular plugs on each end. Plug one end into the jack labeled **L1 OR L2** on the back of the telephone. Place the bundled line cord in the open area under the set.

- **If you have two separate wall jacks**, use both line cords.

Leave the cord with the blue plugs bundled. Plug one end of this cord into the jack labeled **L1 OR L1/L2** on the back of the telephone.

Unbundle the cord with the clear plugs. Plug one end of this cord into the jack labeled **L2** on the back of the phone. Rebundle the cord and store it in the open area under the set.

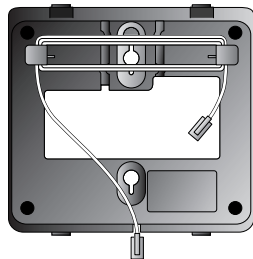

### 2 Attach the base.

Turn the base so that the larger end of the base is toward the bottom of the telephone. Attach the base by inserting the tabs into the slots. Push down on the large end of the base to lock it into place.

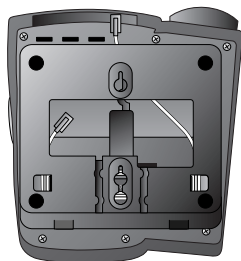
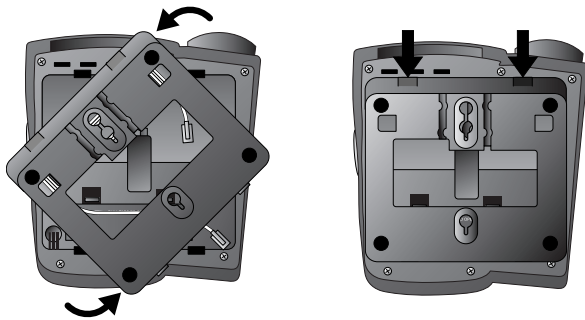

### 3 Reverse handset tab.

To mount the telephone on a wall, you must reverse the handset tab. This tab holds the handset when you hang up.

Hold down the switchhook, and slide the tab up and out of its slot. Turn the tab so that the curved end is up. Insert the tab back into its slot.

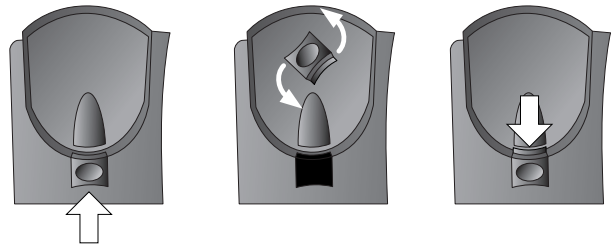

### 4 Connect the line cord(s) to modular wall jack(s) and mount phone onto wall jack.

- **If you have a two-line jack**, plug the free end of the line cord into the modular wall jack. Make sure the cord snaps firmly into place. Place the phone on the wall jack mounting studs and pull down until it is held securely.
- **If you have two separate jacks**, plug the free end of the cord with the blue plugs into the jack for Line 1. Plug the free end of the cord with the clear plugs into the jack for Line 2. Make sure the cords snap firmly into place. Place the phone on the wall jack mounting studs and pull down until it is held firmly in place.

Follow **Steps 4** through **7** under Table Installation.

# TELEPHONE OPERATION

*Line Status Lights*  
 Red on: line in use  
 Red flashing: line on hold  
 Green flashing: line ringing

## Flash

Press **FLASH** instead of pressing the switchhook to activate services such as Call Waiting or 3-Way Calling. You may have to press other buttons before or after **FLASH** as explained in the custom-calling instructions provided by your local telephone company.

## Make a Call

Press a **LINE** button and lift the handset  
 — OR —  
 Press **SPEAKER**  
 — OR —  
 Press **HEADSET**, then dial the call.

## Answer a Call

Press a **LINE** button and lift the handset  
 — OR —  
 Press **SPEAKER**  
 — OR —  
 Press **HEADSET**.

## End a Call

Hang up  
 — OR —  
 Press **SPEAKER** (if on speakerphone call)  
 — OR —  
 Press **HEADSET** (if on headset call).

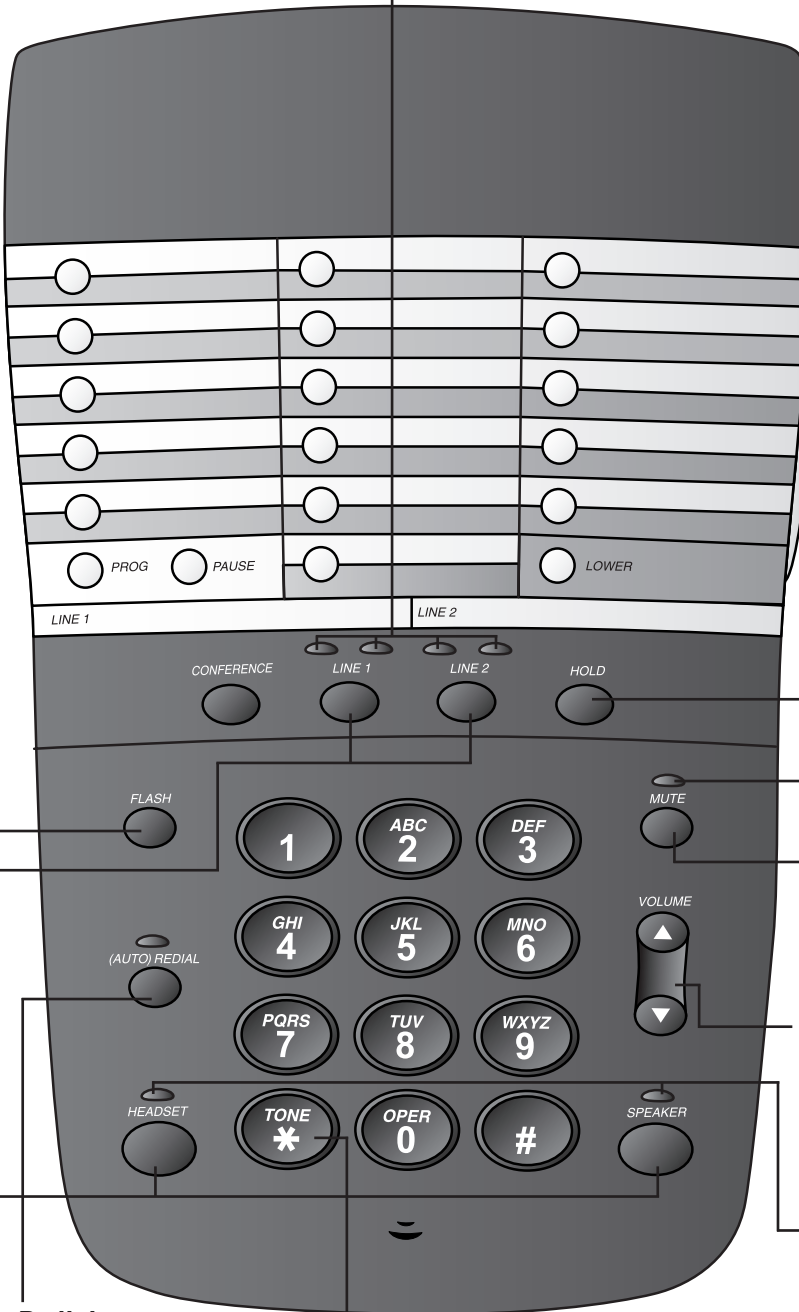

## RINGER Volume

Set each switch to **OFF, LO** or **HI**. You can dial and answer calls normally with one or both switches set to **OFF**.

## Hold

Press to put a line on hold. You can hang up the handset. To return to the call, press the appropriate **LINE** button and lift the handset  
 — OR —  
 Press **HEADSET**  
 — OR —  
 Press **SPEAKER**  
 — OR —  
 Lift the handset of an extension phone on the same line.

*Light is on when MUTE is active.*

## Mute

Press to prevent the other party from hearing you. Press again to return to conversation.

## Handset/Speakerphone/Headset Volume

While on a call press **VOLUME** ▲ to increase, or **VOLUME** ▼ to decrease volume.

*Appropriate light goes on when headset or speakerphone is in use.*

## Redial

Press **LINE 1** or **LINE 2**, then lift the handset  
 — OR —  
 Press **SPEAKER**  
 — OR —  
 Press **HEADSET**, then press **(AUTO) REDIAL** to call the last number (up to 24 digits) dialed on the line.

## Temporary Tone

If you have dial pause (rotary) service you can change from pulse to tone dialing during a call by pressing **\*TONE**.

- 1 Dial the telephone number.
- 2 Press **\*TONE**. All buttons pressed after this send tone signals.
- 3 After you hang up, the phone returns to pulse dialing.

# TELEPHONE OPERATION

## Automatic Redial

This phone can automatically and repeatedly redial the last number you called. Press **LINE 1** or **LINE 2**, then press **(AUTO) REDIAL** without lifting the handset or pressing **(SPEAKER)** or **(HEADSET)**. You will hear the numbers being dialed. When the call is answered, you must either lift the handset or press **(SPEAKER)** or **(HEADSET)** to talk.

If the line called is busy, the phone will redial every 40 seconds up to 10 times (timing begins when the phone is on hook).

To stop automatic redialing at any time, press **(AUTO) REDIAL** again. Lifting the handset or pressing **(SPEAKER)** or **(HEADSET)** will also cancel Automatic Redial.

**NOTE:** This feature will not work if **(CONFERENCE)** is pressed. This feature works when the handset is on hook.

## Switching Between Lines During a Call

During a call on one line, you can make or answer a call on the other line by pressing **(HOLD)**. You can use the **(HOLD)** and **LINE** buttons to switch back and forth between calls as often as necessary.

**Example:** While using Line 1, Line 2 rings:

- 1 Press **(HOLD)** to hold Line 1.
  - 2 Press **LINE 2** to answer the other call.
  - 3 Press **LINE 1** to hang up Line 2 and return to your first call
- OR —
- Press **(HOLD)** to hold Line 2, and press **LINE 1** to return to your first call.

## Conference Calls

You can use both lines at the same time to set up a three-way conference call.

- 1 Make or answer a call and press **(HOLD)**.
- 2 Establish a call on the other line.
- 3 Press **(CONFERENCE)**.
- 4 Hang up to end a conference call.

If one caller hangs up during a conference call, you might hear a dial tone. Press the **LINE** button of the remaining call to disconnect the other line and eliminate the dial tone.

**NOTE:** Under certain circumstances, the far-end parties on a conference call may not hear one another clearly.

## Conference Call Options

**To place a conference call on Hold:**

- 1 Press **(HOLD)** to hold both lines.
- 2 Press **(CONFERENCE)** to release Hold then lift the handset or press **(SPEAKER)** or **(HEADSET)** and continue your conference call.

**To talk privately with one caller:**

- 1 Press the **LINE** button of the person with whom you want to speak privately then lift the handset or press **(SPEAKER)** or **(HEADSET)**.
- 2 Press **(CONFERENCE)** to continue your conference call.

To disconnect one party from a conference call and keep the other on the line, press the **LINE** button of the call you want to continue.

**NOTE:** If you leave the **(CONFERENCE)** button down after a conference call, then dial another number, your call might be completed, but you might hear a busy signal from the other line. Press **(HOLD)**, then press each **LINE** button until you identify the line being used for your completed call.

# TELEPHONE MEMORY

## Storing Memory Numbers

- 1 Lift the handset.
- 2 Press and release **PROG**.
- 3 Enter the telephone number you want to store (up to 24 digits) or press **(AUTO) REDIAL** to store the last number dialed. You will hear a beep each time you press a button. Press **PAUSE** to store a three-second dialing delay.
- 4 Press and release a one-touch location — **OR** — Press and release **LOWER**, then a two-touch location. You will hear a two-beep confirmation tone.
- 5 Hang up.  
Repeat **Steps 1-5** to store another number.

## One-Touch Dialing

The 16 white spaces on the directory card are one-touch memory locations. You can dial one of these numbers by pressing the memory button next to the number.

## Dialing Memory Numbers

- 1 Press **LINE 1** or **LINE 2**.
- 2 Lift the handset — **OR** — Press **SPEAKER** — **OR** — Press **HEADSET** and listen for dial tone.
- 3 Press and release a one-touch memory location — **OR** — Press and release **LOWER** then a two-touch memory location.

## Erasing Numbers

To remove a number from memory, enter another number in the same location. To clear a memory location and leave it empty,

- 1 Press **LINE 1** or **LINE 2**, then lift the handset.
- 2 Press **PROG**.
- 3 Press the button of the memory location you want to clear.

## Directory Card

Remove the plastic cover and the directory card. Write your telephone numbers in the spaces provided, and write the telephone numbers (or names) that you want to store in each memory location. Replace the card and plastic cover in the space provided.

## Two-Touch Dialing

The 16 gray spaces on the directory card are two-touch memory locations. To dial one of these numbers you must press **LOWER**, then the memory button next to the number.

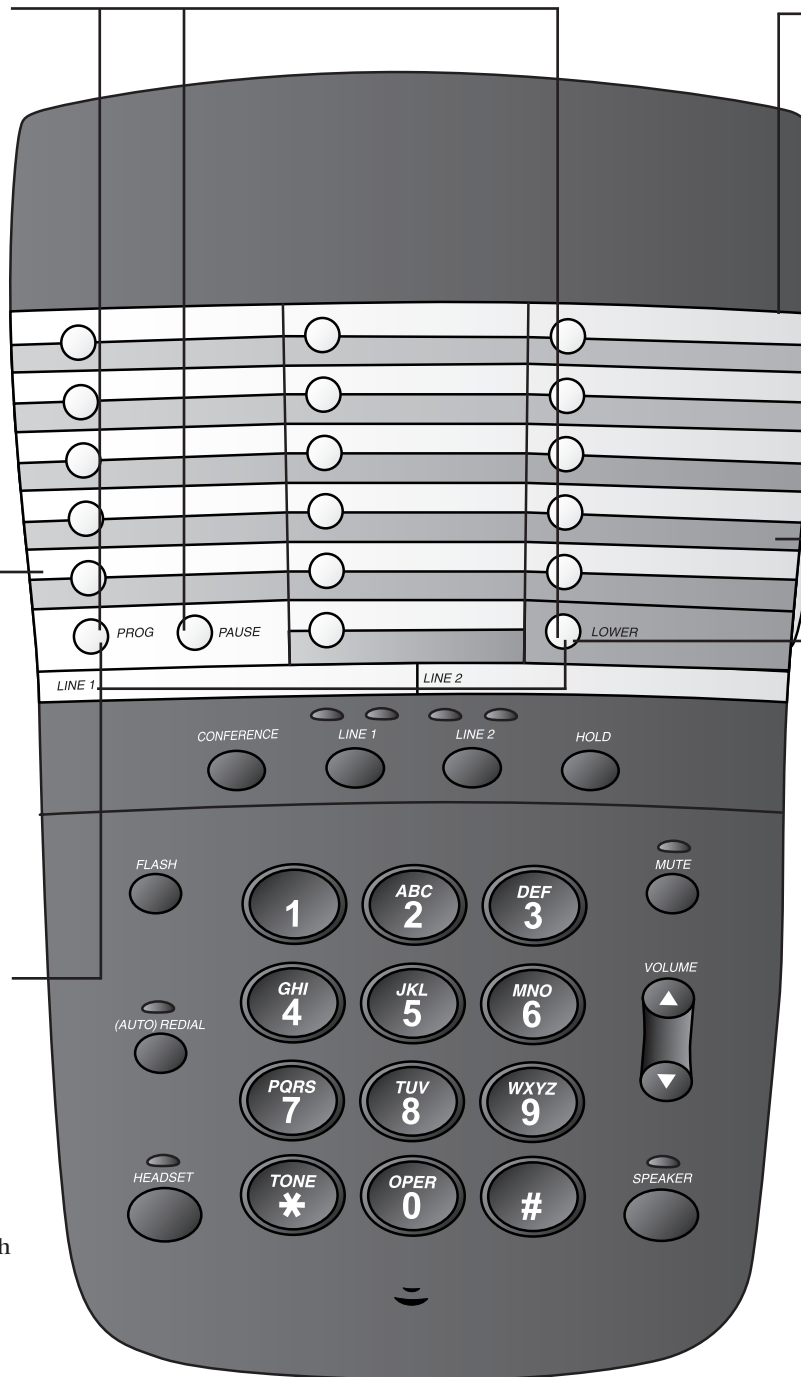

# IN CASE OF DIFFICULTY

If you have difficulty operating this phone, try the suggestions below. For Customer Service, visit our website at [www.telephones.att.com](http://www.telephones.att.com) or call 1 800 222-3111. **Please retain your receipt as your proof of purchase.**

## No Dial Tone

- Make sure all plugs are connected properly. Inspect the line cord connections at the modular jack(s) and at the telephone. Also inspect the coiled handset cord connection at both ends.
- Make sure a line is selected (Line 1 or Line 2).
- Make sure Hold is not activated.
- If you do not hear a dial tone when you press **[HEADSET]**, make sure the headset is firmly connected at the jack.

## Call Cannot Be Dialed Or Is Dialed Slowly

- This product comes set for touch tone (TONE) dialing. Make sure you choose the correct dialing mode, touch tone dialing will not work if you have dial pulse (PULSE) service.
- If you just used Temporary Tone, leave the handset on the base for a few seconds before making another call.

## Automatic Redial Interrupted

- If the phone rings during the Automatic Redial sequence, you will cancel it if you lift the handset, press **[SPEAKER]** or press **[HEADSET]** to take the call.
- Lifting the handset, pressing **[SPEAKER]** or pressing **[HEADSET]** will cancel Automatic Redial.
- Low battery power can affect Automatic Redial. For information about changing batteries, see “Batteries” under INSTALLATION.

## Difficulty Storing Numbers In Memory

- Review “Storing Memory Numbers” under TELEPHONE MEMORY to make sure you are pressing the correct sequence of buttons.
- If you are interrupted by a recorded announcement telling you to hang up (or a loud buzzing noise), hang up and try to enter the number more quickly.
- Try calling the number you want to enter into memory. When the call is ended, press **[PROG]**, **[AUTO REDIAL]** and a memory button.
- If someone lifts an extension phone while you are storing numbers in memory, programming might be interrupted. Make sure all extensions are on hook while storing numbers in memory.
- You might not hear the confirmation beep if the handset volume is set too low, or if you are in a noisy location.
- Do not put the phone on Hold while storing numbers.

## Problems With Line Status Lights

- Make sure all plugs are connected properly. Inspect the line cord connections at the modular jack(s) and at the telephone. Also inspect the coiled handset cord connections at both ends.
- Try replacing old batteries. See “Batteries” under INSTALLATION.
- Make sure the batteries are correctly installed, and that the battery contact surfaces and battery case are clean.
- If only one telephone line is connected, make sure that only the batteries for that line (as labeled on the battery compartment) are installed.

## Cannot Answer Call Pressing **[HEADSET]**

- Make sure the headset is firmly connected at the jack.

## Telephone Does Not Ring

- Make sure the **RINGER** switch is set in the **LO** or **HI** position.
- If there are several other telephones on the same line, try disconnecting some of the other telephones. Having too many telephones connected can also create problems such as low ringer volume, or impaired sound quality during calls.