



THIS MANUAL IS AVAILABLE FOR FREE  
COMPLIMENTS OF

**BUYMEBUYME.COM**

**TO ORDER THIS PRODUCT, PLEASE CALL TOLL-FREE  
1-877-992-8963 OR VISIT [WWW.BUYMEBUYME.COM](http://WWW.BUYMEBUYME.COM)**



USER'S MANUAL  
Part 2

## Four-Line Speakerphone 924

REVISED 8/8/00



For Customer Service Or Product  
Information, Visit Our Website At  
[www.telephones.att.com](http://www.telephones.att.com)

Please also read  
**Part 1 — Important  
Product Information**



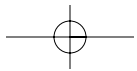

# CONTENTS

<b>INSTALLATION</b> .....	<b>3</b>	<b>TELEPHONE MEMORY</b> .....	<b>17</b>
Table/Desk Installation .....	3	Storing Memory Numbers .....	17
Wall Installation .....	7	Storing a Pause in a Memory Number .....	17
Headset Installation.....	9	Directory Card .....	17
Dial Mode.....	10	Dialing Memory Numbers .....	17
Setting Time and Date.....	10	Viewing Memory Numbers.....	17
<b>TELEPHONE OPERATION</b> .....	<b>11</b>	Dialing Long Numbers.....	18
Automatic Line Selection .....	12	Erasing Memory Numbers .....	18
Making Calls.....	12	<b>IN CASE OF DIFFICULTY</b> .....	<b>19</b>
Answering Calls .....	13		
Changing During a Call.....	13		
Call Volume .....	13		
Mute .....	13		
Redial .....	14		
Automatic Redial.....	14		
Hold .....	14		
Switching Lines During a Call.....	15		
Conference Calls.....	15		
Conference Call Options .....	15		
Flash .....	16		
Temporary Tone Dialing.....	16		
Timer.....	16		
Ringer Volume.....	16		

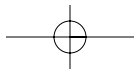
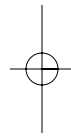

# INSTALLATION

## Table/Desk Installation

### 1 Connect the line cord(s) to telephone.

**Four One-Line Jacks** (To use this installation option, you'll need two two-line adapters. Adapters are available for purchase at retail stores or by calling 1 800 222-3111.)

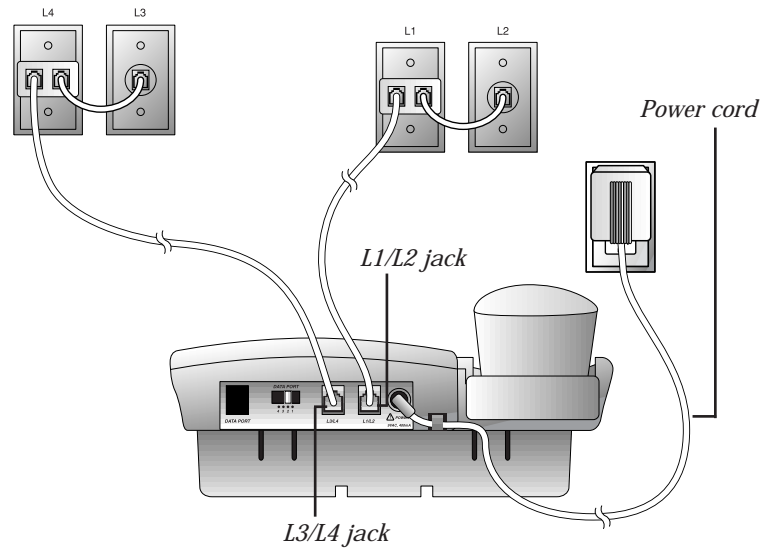

### Two Two-Line Jacks

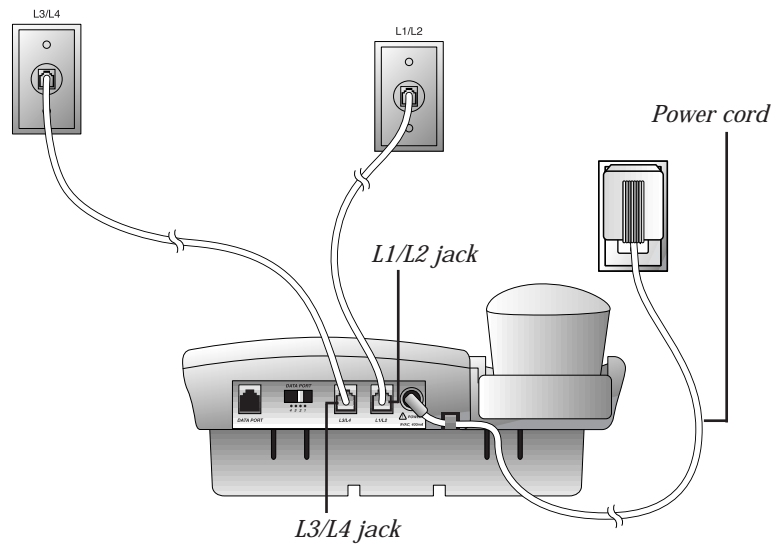

# INSTALLATION

**2 Remove the base.**

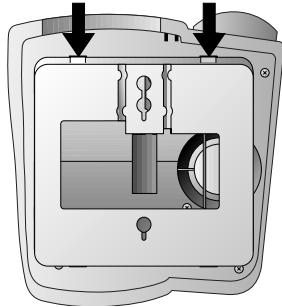

**3 Connect the handset cord.**

Plug one end of the coiled handset cord into the jack on the underside of the phone. Pass the cord through the channel from the jack to the side of the base. Plug the other end into the handset, and hang up.

**4 Replace the base with the widest part at the top.**

# INSTALLATION

## 5 Connect the power adapter.



Use only the power adapter provided with this product. To obtain a replacement, call 1 800 222-3111.

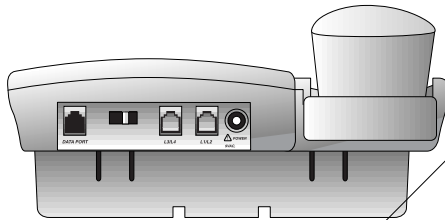

Fit the power cord behind the strain relief tab. Then plug the smaller end into the power jack on the back of the system.

Plug the power cord into an electrical outlet that is not controlled by a wall switch.

**NOTE:** *The power adapter connects the same way whether you use four one-line jacks or two two-line jacks.*

## 6 Check for dial tone.

Press **LINE 1**, lift the handset, and listen for dial tone. Repeat for Lines 2, 3, and 4. If you cannot hear a dial tone, see IN CASE OF DIFFICULTY.

## 7 Confirm Lines 1, 2, 3, and 4.

Make sure none of the lines is in use. Press **LINE 1** and call one of your telephone numbers. If you hear a busy signal, **LINE 1** is the number you called. If another line rings, it is the number you called. Repeat **Step 7** to check all other connected lines.

# INSTALLATION

**NOTE:** If you want to connect another device (such as a modem or fax machine) to the wall jack, you can use the jack on the phone labeled **DATA PORT**. This convenience port uses Line X; a call picked up on Line X at this or another extension may interrupt a fax, modem, or message transmission.

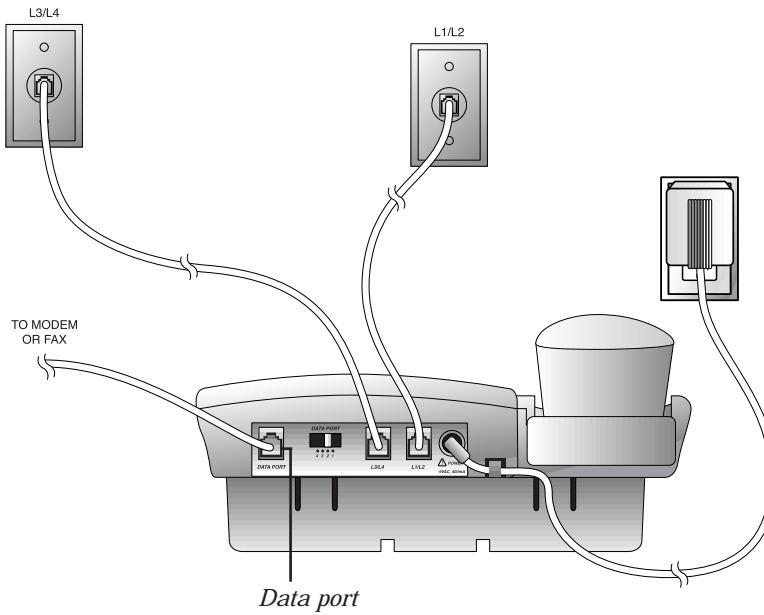

# INSTALLATION

## Wall Installation

### 1 Reverse the handset tab.

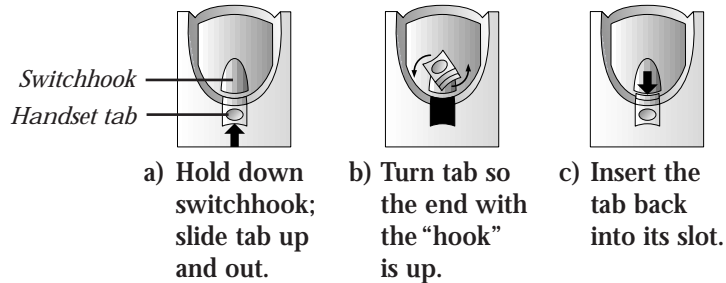

### 2 Remove the base.

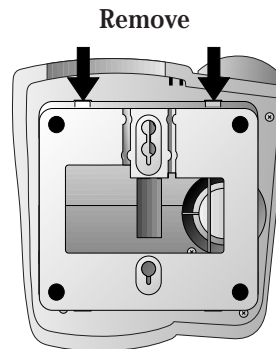

- 3 Connect the bundled line cords to the telephone.**  
Leave the telephone line cords bundled. See **Step 1** in "Table/Desk Installation" for line cord connections.

- 4 Connect the handset cord.**  
Plug one end of the coiled handset cord into the jack on the bottom of the phone. Pass the cord through the channel from the jack to the side of the phone. Plug the other end into the handset, and hang up.

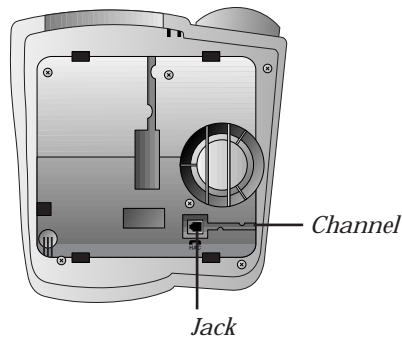

# INSTALLATION

- 5 Turn the base and attach it to the bottom of the phone.**

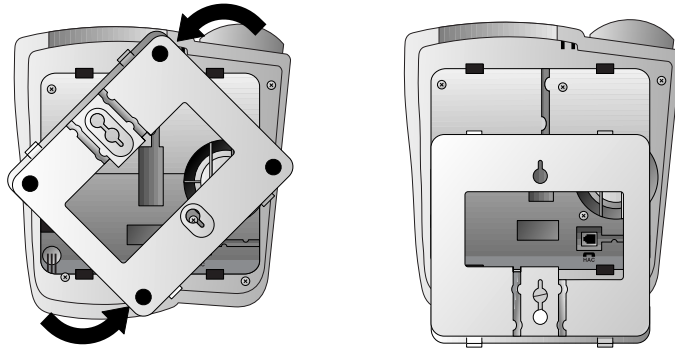

- 6 Connect the power adapter.**

Use only the power adapter provided with this product. To obtain a replacement, call 1 800 222-3111.

Fit the power cord behind the strain relief tab. Then plug the smaller end into the power jack on the back of the system.

Plug the power cord into an electrical outlet that is not controlled by a wall switch.

- 7 Mount the phone on the wall**

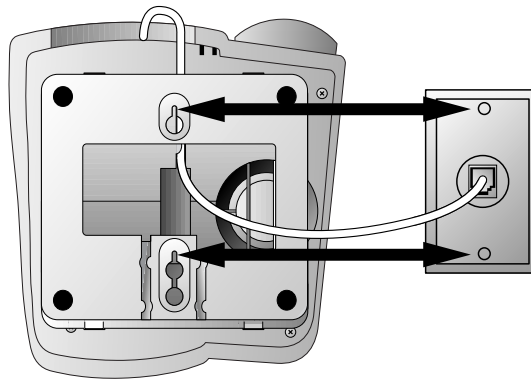

- 8 Follow Steps 6 and 7 under Table/Desk Installation.**

# INSTALLATION

## Headset Installation

You can use this phone hands-free when you install a 2.5 mm headset (purchased separately).

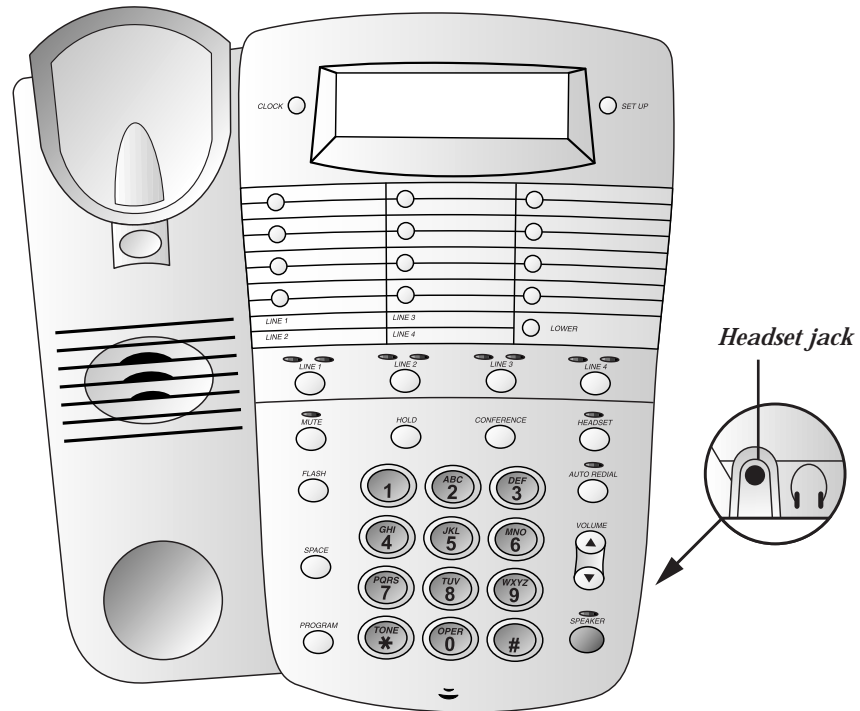

# INSTALLATION

## Dial Mode

This telephone will work with touch tone or dial pulse (rotary) service.

Each line comes set in the tone (t.t.) mode. Make sure you choose the correct dialing method (D.P. or t.t.) for each telephone line; touch tone dialing will not work if you have dial pulse service.

- 1 Press **SET UP**.
- 2 Select the line.
- 3 Press **#**.
- 4 Press **3** to change the dial mode to D.P. (dial pulse)  
— **OR** —  
Press **8** to change the dial mode to t.t. (tone).
- 5 Press **SET UP** to exit  
— **OR** —  
Press a **LINE** button to set the dial mode for that line.

Even when set to dial pulse (D.P.), the phone can be switched temporarily to tone for access to services that require tone signaling, including some tone-activated computer systems. To switch from pulse to tone dialing during a phone call, see “Temporary Tone Dialing” in TELEPHONE OPERATION.

## Setting Time and Date

The screen displays the time and date when the phone is not in use and the ringers are on.

- 1 Press **CLOCK**.
- 2 Use the dial pad to enter the correct time. For example, press **7 5 3** to set the time to 1:53.
- 3 Press **ⓧ** for AM or **#** for PM.
- 4 Enter the correct date. For example, press **9 0 1** to set the date to September 1.
- 5 Press **CLOCK** again.

### To Reset Time Only

Follow **Steps 1–3** above, then press **CLOCK**.

### To Reset Date Only

Follow **Steps 1, 3, 4, and 5** above (skip **Step 2**).

# TELEPHONE OPERATION

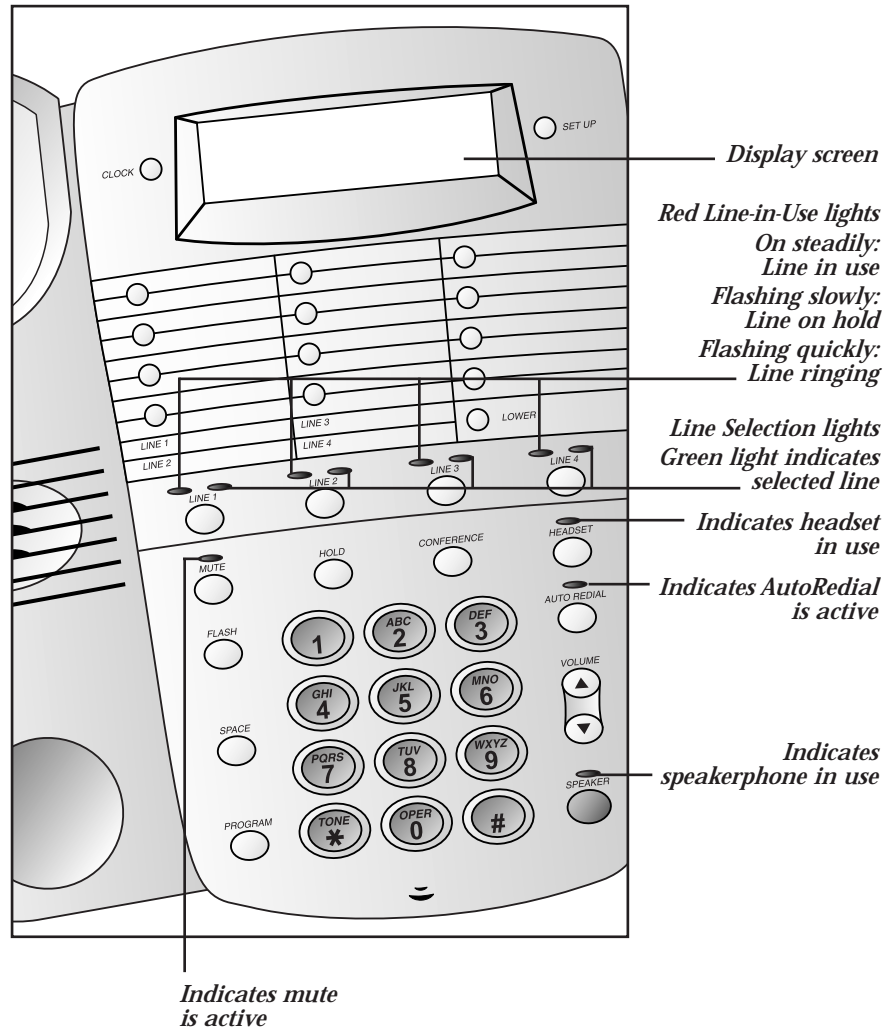

# TELEPHONE OPERATION

## Automatic Line Selection

When you lift the handset, press **[SPEAKER]**, or press **[HEADSET]**, the phone will connect to the prime telephone line. The phone is preset so that Line 1 is the Prime Line.

To change which line the system automatically selects (Prime Line):

- 1 Press **[SETUP]**.
- 2 Select the line you want to act as the Prime Line. The screen displays the status of this line.
- 3 Press **[7]** to choose this line as the new Prime Line. The screen displays the new Prime Line.
- 4 Press **[SETUP]** to exit  
— **OR** —  
Press another **LINE** button to set up that line.

This phone also allows line pre-selection for making and answering calls. If you want to use a specific line, press that **LINE** button and then make or answer your call.

The green Line Selection light indicates which line will be used when making or answering a call.

## Making Calls

You can make calls using the handset, speakerphone, or headset.

- 1 Lift the handset  
— **OR** —  
Press **[SPEAKER]**  
— **OR** —  
Press **[HEADSET]**.

The Prime Line will be selected automatically.

- 2 Dial the call.

**To make a call on a line other than the Prime Line,** press the desired **LINE** button, then follow **Steps 1** and **2** above.

**NOTE:** The red **SPEAKERPHONE** light goes on when the speakerphone is in use. The red **HEADSET** light goes on when the headset is in use.

# TELEPHONE OPERATION

## Answering Calls

Each line has a different ringer tone to signal an incoming call. A red Line-in-Use light will also flash to identify the ringing line.

You can answer and end calls using the handset, speakerphone, or headset.

	Answer a Call	End a Call
	Press LINE button for ringing line, then:	
<b>Handset</b>	Lift handset.	Replace handset.
<b>Speakerphone</b>	Press <b>[SPEAKER]</b> .	Press <b>[SPEAKER]</b> .
<b>Headset</b>	Press <b>[HEADSET]</b> .	Press <b>[HEADSET]</b> .

**NOTE:** When you are using a line and a call is received on another line, the red Line-in-Use light for the ringing line will flash and the set will sound a quiet, short ring for the ringing line.

## Changing During a Call

- To switch from handset to speakerphone while on a call, press **[SPEAKER]** and replace the handset. To switch from speakerphone to handset, lift the handset.
- To switch from handset to headset, press **[HEADSET]** and replace the handset. To switch from headset to handset, lift the handset.
- To switch from speakerphone to headset, press **[HEADSET]**. To switch from headset to speakerphone, press **[SPEAKER]**.

## Call Volume

You can adjust the handset, speaker, or headset volume during your call. Press VOLUME ▲ to increase volume or VOLUME ▼ to lower volume. Volume adjustments for one calling method (handset, headset, or speakerphone) do not affect volume for other methods.

## Mute

Press **[MUTE]** to prevent the other party from hearing you (you will still be able to hear the other party). The MUTE light goes on. Press **[MUTE]** again to continue your conversation.

**NOTE:** This feature works with the handset, speakerphone, and headset. Mute is cancelled if you switch from the handset to speakerphone or headset, or vice versa.

# TELEPHONE OPERATION

## Redial

- 1 Lift the handset, press **[SPEAKER]**, or press **[HEADSET]** and listen for a dial tone. The Prime Line will be selected automatically.
- 2 Press **[AUTO REDIAL]** to call the last number dialed (up to 24 digits).

**To override Prime Line selection**, press the desired LINE button, then follow **Steps 1** and **2** above.

## Automatic Redial

This phone can automatically redial the last number you called up to 10 times.

**NOTE:** To use this feature with a line other than the Prime Line, press a LINE button before **Steps 1** and **2** below.

- 1 Press **[AUTO REDIAL]** without lifting the handset, pressing **[SPEAKER]**, or pressing **[HEADSET]**. You will hear the number being dialed. If the called number is busy, the phone redials every 60 seconds (up to 10 times).
- 2 When the call is answered, lift the handset, press **[SPEAKER]**, or press **[HEADSET]** to talk.

To stop automatic redialing at any time, press **[AUTO REDIAL]** again. Lifting the handset, pressing **[SPEAKER]** or pressing **[HEADSET]** to make a call will also cancel automatic redial.

**NOTE:** This feature cannot be used to add a third party to an existing call (conferencing). This feature only works when the phone is not in use.

## Hold

When a call is put on hold, nothing either party says can be heard, and the red Line-in-Use light for the held line flashes. You cannot access any special features.

- 1 Press **[HOLD]**. If you are using the handset, you can place the phone in the cradle.
- 2 To return to the conversation, press the appropriate LINE button, then lift the handset, press **[SPEAKER]** or press **[HEADSET]** (if you do not select a line, you will be connected to the Prime Line)  
— **OR** —  
Lift the handset of an extension phone of the line on hold.

# TELEPHONE OPERATION

## Switching Lines During a Call

During a call on one line, you can make or answer a call on another line by pressing **HOLD**. You can use the **HOLD** and **LINE** buttons to switch back and forth between calls as often as necessary. **Example:** While using Line 1, Line 2 rings:

- 1 Press **HOLD** to hold Line 1.
- 2 Press **LINE 2**, then lift the handset, press **SPEAKER** or press **HEADSET** to answer the other call.
- 3 Press **LINE 1**, then lift the handset, press **SPEAKER** or press **HEADSET** to hang up Line 2 and return to your first call  
— **OR** —  
Press **HOLD** to hold Line 2, press **LINE 1**, then lift the handset, press **SPEAKER** or press **HEADSET** to return to your first call.

## Conference Calls

You can use two lines at the same time to set up a three-way conference call.

- 1 Make or answer a call, and press **HOLD**.
- 2 Establish a call on another line.
- 3 Press **CONFERENCE**.
- 4 Hang up to end a conference call.

If one caller hangs up during a conference call, you might hear a dial tone. Press the **LINE** button of the remaining call to disconnect the other line and eliminate the dial tone.

## Conference Call Options

### To place a conference call on hold:

- 1 Press **HOLD** to put both lines on hold.
- 2 Press **CONFERENCE** to release hold and continue the conference call.

**NOTE:** *If more than one line is on hold, you cannot form a conference while talking to a third party.*

### To talk privately with one caller:

- 1 Press **HOLD**.
- 2 Press the **LINE** button of the person with whom you want to speak privately.
- 3 Press **CONFERENCE** to return to your conference call.

To disconnect one party from a conference call and keep the other one on the line, press the **LINE** button of the call you want to continue.

# TELEPHONE OPERATION

## Flash

The Flash feature is useful if you have subscribed to custom calling services from your local telephone company. Press **FLASH** instead of pressing the switchhook to activate services such as Call Waiting or Three-Way Calling. You may have to press other buttons before or after **FLASH** as explained in the custom calling instructions provided by your local telephone company. The **FLASH** button is used only as a substitute for pressing the switchhook.

## Temporary Tone Dialing

If you have dial pulse (rotary) service, you can change from dial pulse to touch tone dialing during a call by pressing **⊗**. This is useful if you need to send touch tone signals for access to telephone banking or long-distance services.

- 1 Dial the number.
- 2 Press **⊗**. Buttons pressed after this send touch tone signals.
- 3 After you hang up, the phone automatically returns to dial pulse (rotary) service.

## Timer

The timer starts automatically when you make or answer a call and will appear on the screen approximately 40 seconds into the call.

The screen displays elapsed time in minutes and seconds. (After one hour the timer resets to 00:00 and begins again.)

The timer stops automatically when you hang up. The screen displays the recorded time for about 10 seconds.

## Ringer Volume

You must set the ringer volume independently for each line.

- 1 Press **SET UP**.
- 2 Press the **LINE** button for the line whose volume you want to set.
- 3 Press **VOLUME ▲** to increase volume for the selected line  
— **OR** —  
Press **VOLUME ▼** to lower volume. Setting to the lowest volume level (0) turns off the ringer for that line.

**NOTE:** Follow **Steps 2 and 3** to adjust ringer(s) when the phone is not in use.

# TELEPHONE MEMORY

## Storing Memory Numbers

- 1 Press **PROGRAM**.
- 2 Dial the telephone number (up to 24 digits). To enter a space between digits, press **SPACE** once.  
— **OR** —  
Press **AUTO REDIAL** to store the last number dialed.
- 3 Press a memory button  
— **OR** —  
Press **LOWER**, then press a memory button.
- 4 Repeat **Steps 2** and **3** to store another number.
- 5 Press **PROGRAM** to exit programming mode.

**NOTE:** If you do not press **PROGRAM**, the number will be stored and the phone will exit programming automatically after about two seconds.

## Storing a Pause in a Memory Number

You can program a three-second pause in the dialing sequence of a memory number. While storing a memory number, press **LOWER**, **SPACE** where you want the pause to occur.

**NOTE:** Every memory location can store 24 digits. Each three-second pause counts as one digit.

## Directory Card

Remove the plastic cover and the directory card. Write your telephone numbers in the spaces provided, and write the telephone numbers (or names) stored in each memory location. Reinstall the card and plastic cover.

## Dialing Memory Numbers

- 1 Lift the handset, press **SPEAKER** or press **HEADSET**. The Prime Line is automatically selected. Listen for a dial tone.
- 2 Press a memory button  
— **OR** —  
Press **▼**, then press a memory button.

## Viewing Memory Numbers

To view a number when the telephone is not in use, press the memory button where the number is stored. The number displayed on the screen will not be dialed.

# TELEPHONE MEMORY

## Dialing Long Numbers

### Use Two Memory Locations

You can store a dialing sequence of more than 24 digits by dividing it and storing it in two memory locations (see “Storing Memory Numbers”). To dial:

- 1 Get a dial tone.
- 2 Press the memory button for the first location, and wait for dialing to stop.
- 3 Press the memory button for the second location.

### Combine Manual and Memory Dialing

You can store part of a long number in a memory location. To dial, use the memory button for the stored portion and manually dial the other digits. If the stored portion is dialed first, wait for dialing to stop before you continue with manual dialing.

## Erasing Memory Numbers

To remove a number from memory, store another number in its place. To clear a memory location and leave it empty:

- 1 Press **PROGRAM**.
- 2 Press the location of the memory location you want to clear.
- 3 Press **PROGRAM**.

## IN CASE OF DIFFICULTY

If you have difficulty operating this phone, try the suggestions below. For Customer Service, visit our website at [www.telephones.att.com](http://www.telephones.att.com) or call 1 800 222-3111. **Please retain your receipt as your proof of purchase.**

### No Dial Tone

- Make sure all plugs are connected properly. Inspect the line cord connections at the modular jack and at the telephone. Also inspect the coiled handset cord connections at both ends.
- Unplug the telephone and connect it to another modular jack. If it still does not work, and other telephones in your home are working, the problem is with this telephone.

### Call Cannot Be Dialed or Is Dialed Slowly

- Make sure you chose the correct Dial Mode (see INSTALLATION). If you have dial pulse service, you cannot dial numbers with the phone set to touch tone dialing.
- If you have just used the Temporary Tone feature, leave the handset on the base for a few seconds before making another call.

### Automatic Redial Interrupted

Lifting the handset, pressing **[SPEAKER]** or **[HEADSET]**, or pressing a LINE button to make a call will cancel Automatic Redial.

### Difficulty Storing Numbers in Memory

- Make sure you are pressing the correct sequence of buttons for storing numbers.
- If you are interrupted by a recorded announcement telling you to hang up or by a loud buzzing noise, hang up and enter the number while the phone is not in use.
- Try calling the number you want to store in memory. When the call is ended, press **[PROGRAM]**, **[AUTO REDIAL]**, and a memory button.

### Problems with Line-in-Use Lights or Line Selection Indicators

Make sure all plugs are connected properly. Inspect the line cord connections at the modular jack and at the telephone. Also inspect the coiled handset cord connections at both ends.

## IN CASE OF DIFFICULTY

### Telephone Does Not Ring

- Make sure the ringer volume for this line is not set to 0.
- If there are several other telephones on the same line, try disconnecting some of the other telephones. Having too many telephones connected can also create problems such as low ringer volume or impaired sound quality during calls.